

SCH Technologies

Conformal Coating Services, Equipment,
Technical Support & Humiseal Materials.

CB100 Conformal Coating Spray Booth System

Overview

Batch Spray Coating is one of the most flexible methods for application of conformal coatings and is excellent for all volume production whether large or small.

The process of spraying circuit boards with a conformal coating material using a high quality spray gun ensures complete coverage, including excellent tip coverage of components which can be a major issue.

Specification

The CB100 Conformal Coating Spray Booth System is a precision built, floor standing, conformal coating spray booth for low to medium volume batch processing of printed circuit boards.

The following standard features are included:

- Low Level Workbench to minimise operator fatigue whilst applying conformal coating
- High quality, dual UVA and white lighting for conformal coating inspection whilst spraying and maintenance
- Manual turntable for full 360° rotation for complete coverage
- Easy use, low cost two layer mesh filtration system
- Fitted two-door storage cupboard for utensils, spares, pressure pots
- ESD Points fitted for full anti-static protection
- Exterior powder coated WHITE, interior brushed stainless steel
- Fabricated from strong, durable steel panels with fully riveted seams

Options

- Automatic Turntable for 90 degrees indexing of PCBs
- dual stainless steel pressure pot system for optimised spray coating with minimal down time on operation
- Teflon coated internal panels
- Internal shelf for PCB storage
- full-face breathing apparatus for highly hazardous materials
- Solvent exposure alarms including data-logging for in-situ real time monitoring of operator safety
- Custom designs and size options

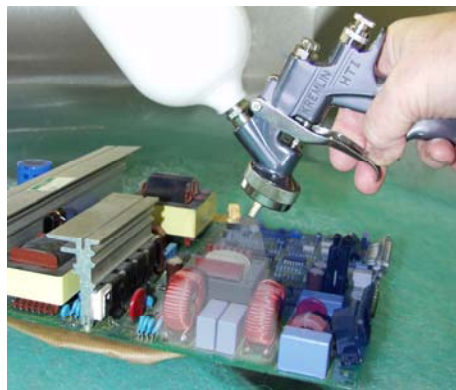

SCH Technologies

Conformal Coating Services, Equipment,
Technical Support & Humiseal Materials.

Schematic of DS101 Layout

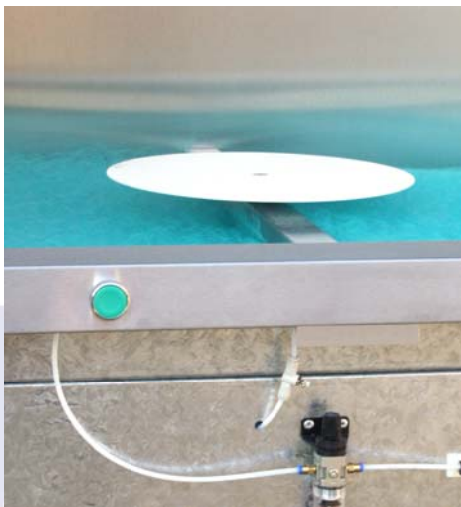
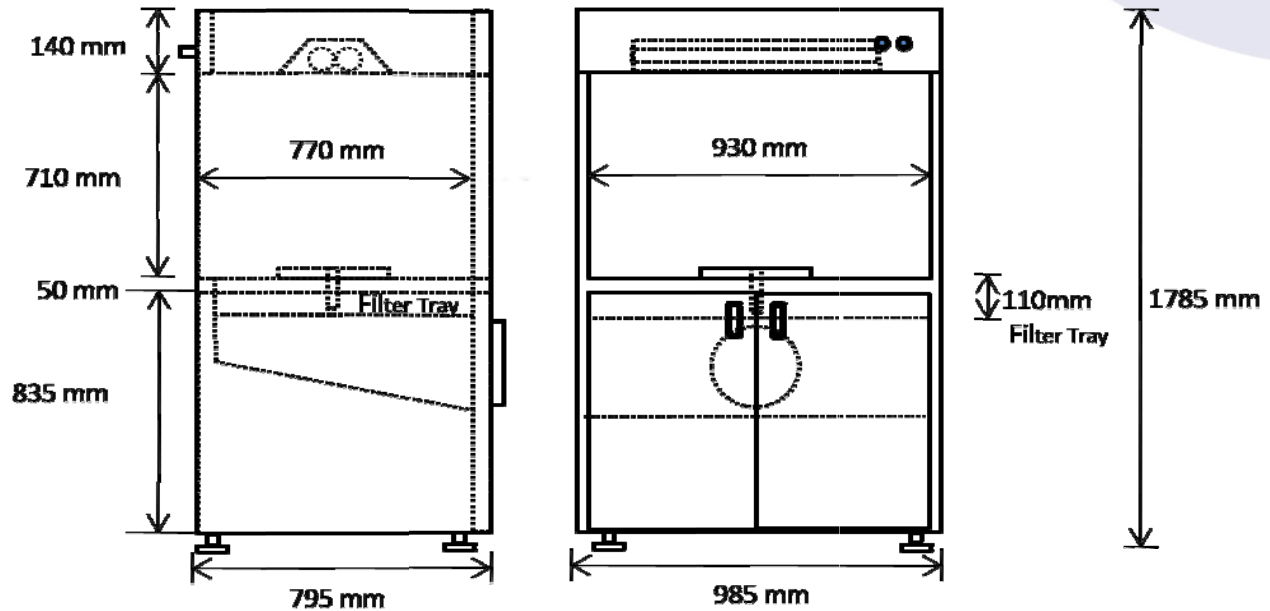

System Specification

- Weight: approx 150kg
- Door size: 460 x 835 mm
- Extraction vent: 305 mm diameter

Services required:

- 80psi clean, dry air supply
- 8mm push fit air inlet
- 980 Cubic ft per min (CFM) extraction (0.7 m/s air velocity)
- 13A Single phase electricity supply

SCH Technologies offer

- Conformal coating Subcontract Services
- Global supply of Conformal Coating Application Equipment
- Humiseal Conformal Coatings
- Conformal Coating Training courses
- Conformal Coating Consultation & troubleshooting

PLEASE CHECK OUR WEBSITE FOR DETAILS

www.conformalcoating.co.uk

SCH Technologies is a Trading Name of SCH Services Limited
Unit B, 4 Wharnclyffe Street, Barnsley, South Yorkshire. S70 6BP
Tel: +44 (0)1226 297711 Fax: +44 (0)1226 297733
www.conformalcoating.co.uk
sales@schservices.com